



C Shaft Rings

Reference Part # 5103

Radially Assembled, External Crescent

Ideal for low clearance applications where radial installation is preferred.

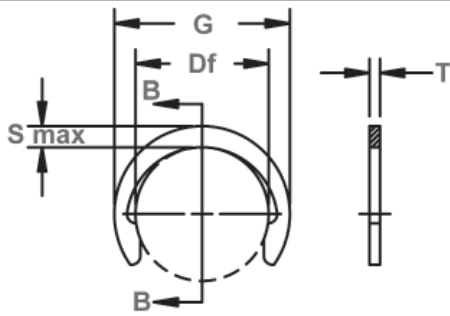

Free Diameter & Ring Measurements with Section B-B

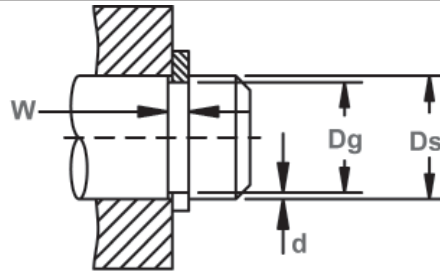

Shaft Diameter & Groove Dimensions

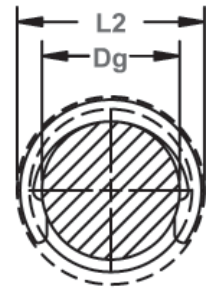

Clearance Diameter Installed In Groove

RING NO.	SHAFT DIAMETER			GROOVE SIZE					RING SIZE & WEIGHT				CLEARANCE DIA.			THRUST LD. (lbs.)	
				DIAMETER		WIDTH		DEPTH	FREE DIAMETER		THICKNESS**		Wght. Per 1000 Pcs.	Free outside dia. REF.	Re-leased in groove	Sqr. Corner Abutment	
	Ds DEC	Ds FRACT	Ds mm	Dg	Tol.	W	Tol.	d	Df	Tol.	T	Tol.				lbs.	G
C-12	.125	1/8	3.2	.106	±.0015	.020	+ .002	.0095	.102	+ .002	.015		.030	.165	.18	86	45
C-15	.156	5/32	4.0	.135	*.0015	.020	- .000	.0105	.131	- .004	.015		.052	.205	.22	102	55
C-18	.188	3/16	4.8	.165		.020		.011	.161		.015		.062	.244	.25	132	70
C-21	.219	7/32	5.6	.193	±.002*.0015	.029		.013	.187		.025		.120	.275	.29	264	100
C-23	.236	15/64	6.0	.208	±.002*.002	.029		.014	.203		.025		.15	.295	.31	284	115
C-25	.250	1/4	6.4	.220		.029		.015	.211	+ .003	.025		.157	.311	.33	294	130
C-28	.281	9/32	7.1	.247		.029		.017	.242	- .005	.025		.19	.346	.36	335	165
C-31	.312	5/16	7.9	.276	±.002	.029		.018	.270		.025		.226	.376	.39	376	200
C-37	.375	3/8	9.5	.335	*.002	.029		.020	.328		.025		.300	.448	.47	447	270
C-40	.406	13/32	10.3	.364		.029		.021	.359		.025		.352	.486	.50	487	300
C-43	.438	7/16	11.1	.393		.029		.022	.386		.025		.359	.517	.53	528	350
C-50	.500	1/2	12.7	.450		.039	+ .003	.025	.441	±.006	.035	±.002	.671	.581	.60	842	450
C-56	.562	9/16	14.3	.507		.039	- .000	.028	.497		.035		.710	.653	.67	944	550
C-62	.625	5/8	15.9	.563		.039		.031	.553		.035		.937	.715	.74	1045	700
C-68	.688	11/16	17.5	.619	±.003	.046		.034	.608		.042		1.3	.784	.80	1726	800
C-75	.750	3/4	19.0	.676	*.004	.046		.037	.665		.042		1.5	.845	.87	1878	1000
C-81	.812	13/16	20.6	.732		.046		.040	.721	±.007	.042		1.7	.915	.94	2040	1150
C-87	.875	7/8	22.2	.789		.046		.043	.777		.042		2.0	.991	1.01	2202	1300
C-93	.938	15/16	23.8	.843		.046		.047	.830		.042		2.3	1.058	1.08	2355	1550
C-100	1.000	1	25.4	.900		.046		.050	.887		.042		2.7	1.130	1.15	2517	1800
C-112	1.125	1-1/8	28.6	1.013		.056		.056	.997		.050		4.0	1.267	1.30	3370	2200
C-125	1.250	1-1/4	31.7	1.126	±.004	.056		.062	1.110	±.008	.050		5.1	1.415	1.44	3735	2700
C-137	1.375	1-3/8	34.9	1.237	*.005	.056	+ .004	.069	1.220		.050		6.1	1.555	1.58	4111	3350
C-150	1.500	1-1/2	38.1	1.350		.056	- .000	.075	1.331		.050		7.6	1.691	1.72	4486	4000
C-162	1.625	1-5/8	41.3	1.483	±.005	.068		.071	1.463		.062		11.0	1.853	1.88	5506	4650
C-175	1.750	1-3/4	44.4	1.576	*.005	.068		.087	1.555	±.010	.062	±.003	12.9	1.975	2.01	6526	5300
C-200	2.000	2	50.8	1.800		.068		.100	1.777		.062		16.2	2.257	2.30	7410	7000

*F.I.M.(FULL INDICATOR MOVEMENT)-MAXIMUM ALLOWABLE DEVIATION OF CONCENTRICITY BETWEEN GROOVE AND SHAFT.

† BASED ON HOUSINGS/SHAFTS MADE OF COLD ROLLED STEEL. FOR AN EXPLANATION OF FORMULAS USED TO DERIVE THRUST LOAD AND OTHER PERFORMANCE DATA, CONTACT THE ROTOR CLIP ENGINEERING DEPT.

** FOR PLATED RINGS ADD .002" TO THE LISTED MAXIMUM THICKNESS. MAXIMUM RING THICKNESS WILL BE A MINIMUM OF .0002" LESS THAN THE LISTED GROOVE WIDTH (W) MINIMUM.

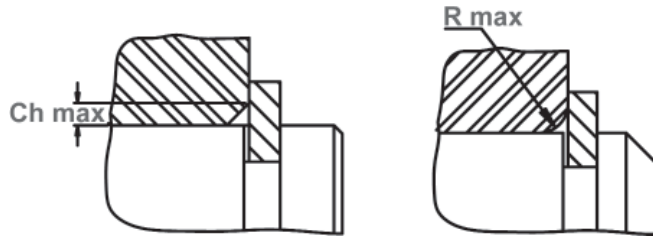

Maximum Corner Radius & Chamfer

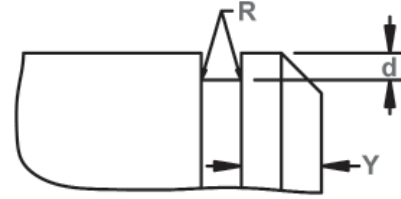

Enlarged Groove Profile & Edge Margin (Y)
Maximum bottom radii (R), .005 For rings sizes
-12 thru -43; .010 For ring sizes -46 thru -100;
.015 For sizes -112 thru -200

RING NO.	MAXIMUM SECTION		ALLOWABLE CORNER RADII & CHAMFERS		MAX LOAD w/ R max or Ch max (in lbs.)	EDGE MARGIN		R.P.M. LIMITS Standard material
	S max	Tol.	R max	Ch max		P'r	Y	
C-12	.031	± .003	.014	.011	85	.020	80000	
C-15	.037		.018	.014	100	.020	75000	
C-18	.042		.021	.016	110	.022	73000	
C-21	.044		.021	.016	260	.026	71000	
C-23	.046	± .004	.022	.017	275	.028	62000	
C-25	.050		.023	.018	290	.030	60000	
C-28	.051		.021	.016	310	.034	56000	
C-31	.053		.024	.018	310	.036	52000	
C-37	.060		.026	.020	310	.040	43000	
C-40	.063		.027	.021	310	.042	40000	
C-43	.065	± .005	.029	.022	310	.044	31000	
C-50	.070		.030	.023	610	.050	25000	
C-56	.078		.033	.025	610	.056	22000	
C-62	.081		.033	.025	610	.062	20000	
C-68	.086		.034	.026	880	.068	18500	
C-75	.090		.036	.027	880	.074	17500	
C-81	.097		.038	.029	880	.080	16000	
C-87	.105		.040	.031	880	.086	15000	
C-93	.112	± .007	.043	.033	880	.094	14000	
C-100	.120		.046	.035	880	.100	12500	
C-112	.135		.052	.040	1250	.112	11500	
C-125	.150		.057	.044	1250	.124	10500	
C-137	.165		.062	.048	1250	.138	9500	
C-150	.180		.069	.053	1250	.150	8500	
C-162	.195		.075	.058	1920	.162	8000	
C-175	.210		.081	.062	1920	.174	7500	
C-200	.240	.091	.070	1920	.200	6000		

LARGER SIZES MAY BE AVAILABLE UPON REQUEST.

HARDNESS RANGES: STAINLESS STEEL RINGS (PH 15-7MO)

RING TYPE	SIZE RANGE	SCALE	ROCKWELL HARDNESS
C	12-18	15N	82.5-86*
	21-81	30N	63-69.5
	87+	C	44-51

HARDNESS RANGES: BERYLLIUM COPPER RINGS

RING TYPE	SIZE RANGE	SCALE	ROCKWELL HARDNESS
C	12-62	15N	77-82*
	68-81	30N	54-62
	87+	C	34-43

HARDNESS RANGES: CARBON STEEL RINGS (SAE 1060-1090)

RING TYPE	SIZE RANGE	SCALE	ROCKWELL HARDNESS
C	12-18	15N	86-88.5*
	21-43	30N	67.5-72
	50-81	30N	66-71
	87+	C	47-52

*HARDNESS CAN NOT BE CHECKED WITH ANY DEGREE OF ACCURACY DIRECTLY ON THESE RINGS.