



TI Housing Rings

Reference Part # 5005

Internal, Self-Locking Push-On

The internal version of the TY featuring a series of prongs protruding outward. The ends create interference with the housing when the ring is installed and a load introduced to the other side.

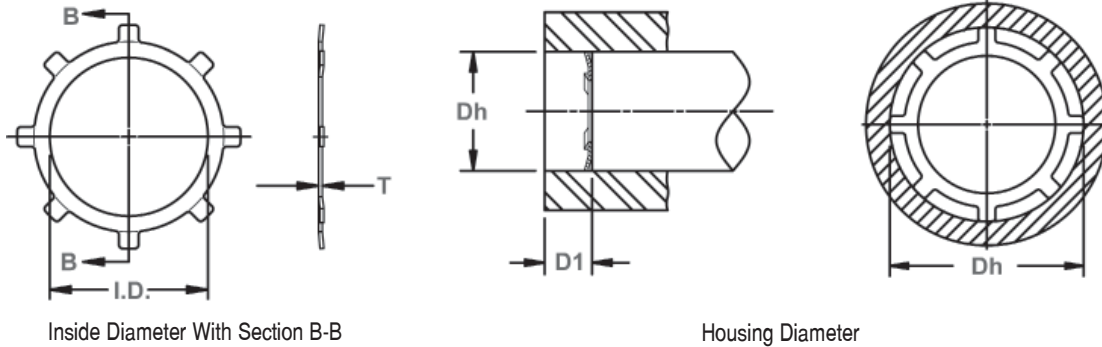

Inside Diameter With Section B-B

Housing Diameter

RING NO.	HOUSING DIAMETER				RING SIZE & WEIGHT						Min. Distance Face of part to end of housing				
					INSIDE DIAMETER		THICKNESS***		No. of Prongs	Thrust Load		Weight Per 1000 Pcs.			
	FROM	TO	Dh FRACT	Dh mm	I.D.	Tol.	T	Tol.					lbs.	lbs.	D1
TI-31	.311	.313	5/16	7.92	.136	±.005	.010	±.001	6	81	.11	.040			
TI-37	.374	.376	3/8	9.53	.175				6	76	.16	.040			
TI-43	.437	.439	7/16	11.13	.237				6	71	.20	.040			
TI-44	.440	.442	-	11.20	.258				6	41	.18	.040			
TI-50	.498	.502	1/2	12.7	.258				6	61	.24	.040			
TI-56	.560	.564	9/16	14.27	.312				6	51	.29	.040			
TI-62	.623	.627	5/8	15.85	.390				6	46	.30	.040			
TI-63	.638	.640	-	16.23	.390				6	43	.32	.040			
TI-75	.748	.752	3/4	19.05	.500				±.010	.015	±.002	8	76	.62	.060
TI-87	.873	.877	7/8	22.23	.625							8	71	.75	.060
TI-93	.936	.940	15/16	23.83	.687	10	71	.85				.060			
TI-100	.998	1.002	1	25.4	.750	10	75	.91				.060			
TI-112	1.123	1.127	1 1/8	28.58	.813	10	60	1.30				.060			
TI-125	1.248	1.252	1 1/4	31.75	.938	10	60	1.50				.060			
TI-143	1.436	1.44	1 7/16	36.51	1.117	12	60	1.73				.060			
TI-150	1.498	1.502	1 1/2	38.10	1.188	12	60	1.80				.060			
TI-175	1.748	1.752	1 3/4	44.45	1.438	12	55	2.10				.060			
TI-200	1.998	2.002	2	50.80	1.600	14	55	3.00				.060			

*** FOR PLATED RINGS ADD .002" TO MAXIMUM THICKNESS.
LARGER SIZES MAY BE AVAILABLE UPON REQUEST.

† BASED ON HOUSINGS/SHAFTS MADE OF COLD ROLLED STEEL. FOR AN EXPLANATION OF FORMULAS USED TO DERIVE THRUST LOAD AND OTHER PERFORMANCE DATA, CONTACT THE ROTOR CLIP ENGINEERING DEPT.
THRUST LOAD CAPACITY IF APPLICABLE TO PARTS MADE FROM CARBON SPRING STEEL AND STAINLESS STEEL MATERIALS ONLY.

Cross Reference Example
5005-31 = **TI-31**

HARDNESS RANGES: STAINLESS STEEL RINGS (PH 15-7MO)

RING TYPE	SIZE RANGE	SCALE	ROCKWELL HARDNESS
TI	31-62	15N	82.5-86*
	75+	15N	82.5-86

HARDNESS RANGES: BERYLLIUM COPPER RINGS

RING TYPE	SIZE RANGE	SCALE	ROCKWELL HARDNESS
TI	31-62	15N	77-82*
	75+	15N	77-82

HARDNESS RANGES: CARBON STEEL RINGS (SAE 1060-1090)

RING TYPE	SIZE RANGE	SCALE	ROCKWELL HARDNESS
TI	31-62	15N	84-86*
	75+	15N	84-86

*HARDNESS CAN NOT BE CHECKED WITH ANY DEGREE OF ACCURACY DIRECTLY ON THESE RINGS.